



## GENUINE PARTS

### INSTALLATION INSTRUCTIONS

**DESCRIPTION:** Rear Bumper Protector

**APPLICATION:** Pathfinder

**PART NUMBER:** T99B1 9PJ0A

**KIT CONTENTS:**

Item	Qty.	Part Description	Service Part Number
A	1	Rear Bumper Protector	N/A
B	2	Spacer Blocks	N/A
C	1	Installation Instruction Replacement Template	N/A
D	2	90% Alcohol Prep Pads	N/A

**TOOLS REQUIRED:**

- Clean, Lint-Free Wiping Cloth
- Masking Tape

**PRE-INSTALLATION WARNINGS, CAUTIONS, CRITICAL STEPS, and NOTES:**

- Dealer installation recommended. Instructions may refer to Service Manual.

### CAUTION

- Install bumper protector only when part and vehicle temperature are between 16°C - 43°C (60°F - 110°F).

**INSTALLATION PROCEDURE:**

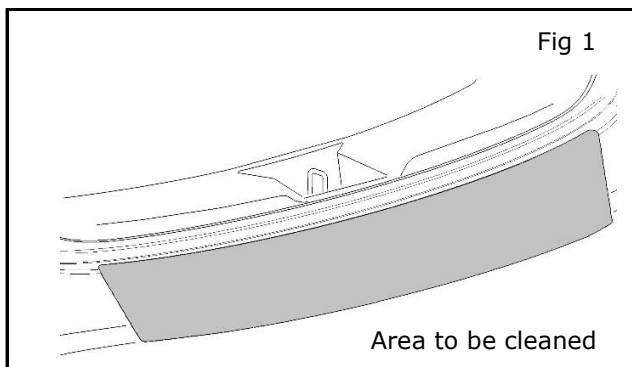

- 1) Clean vehicle area thoroughly with soap and water to remove any dirt or debris. Allow to dry completely.
- 2) Bumper protector installation prep.
  - a) Open rear hatch.
  - b) Using a clean lint-free cloth and 90% isopropyl alcohol prep pads, clean area of rear bumper where part will be installed.
  - c) Allow time to dry thoroughly.

### CAUTION

**Failure to clean mounting surface properly may cause tape to have poor adhesion to vehicle.**

## INSTALLATION PROCEDURE:

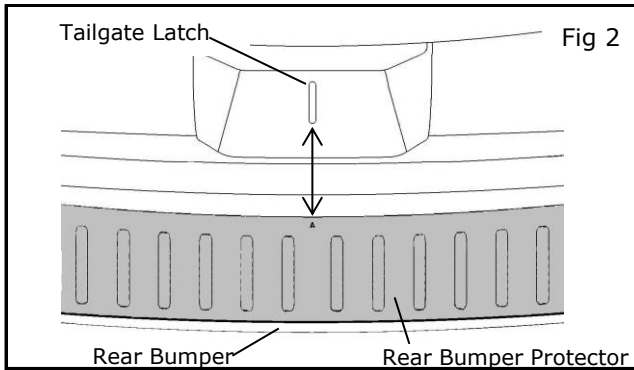

- 3) Dry fit bumper protector on vehicle by aligning bumper protector centering arrow with tailgate latch.

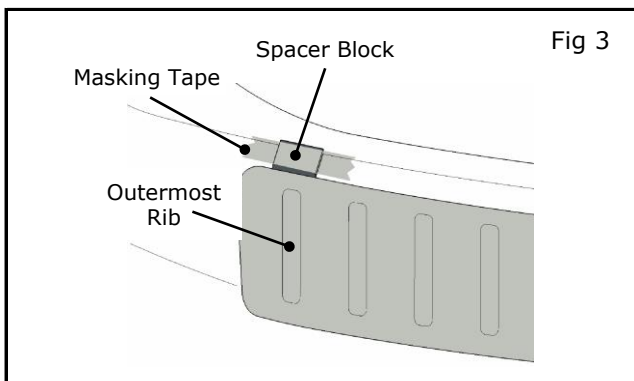

- 4) Position spacer block in alignment with outermost rib feature on both sides of vehicle. Spacer block should fit tightly between part and bumper.
- 5) Secure spacer block to bumper with masking tape.

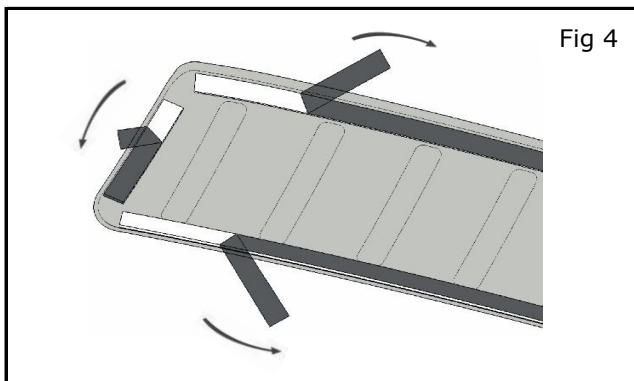

- 6) Prepare tape.
  - a) Remove part.
  - b) Peel back approximately 30mm (1¼in) on all tape liners.
  - c) Fold back all liners to make them accessible from edge of part.

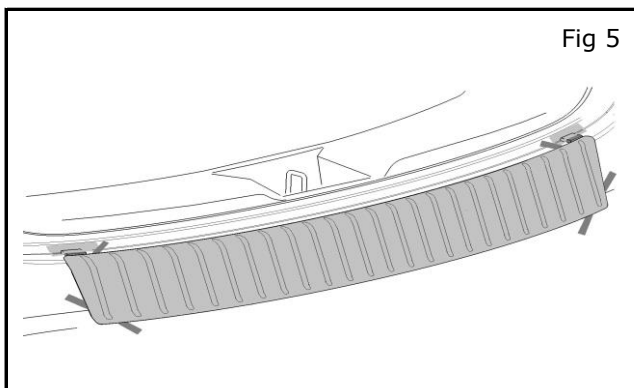

- 7) Re-align part to vehicle, and lightly tack part to vehicle.
- 8) Confirm center arrow alignment to vehicle and tight fit to spacers. Confirm curved rear edge of part does not rest on bumper. If necessary, un-tack part and repeat.

## CAUTION

**Tape will not properly tack if curved rear edge of part rest on bumper.**

## INSTALLATION PROCEDURE:

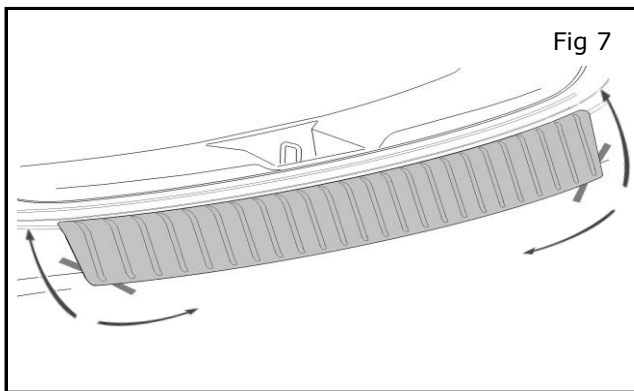
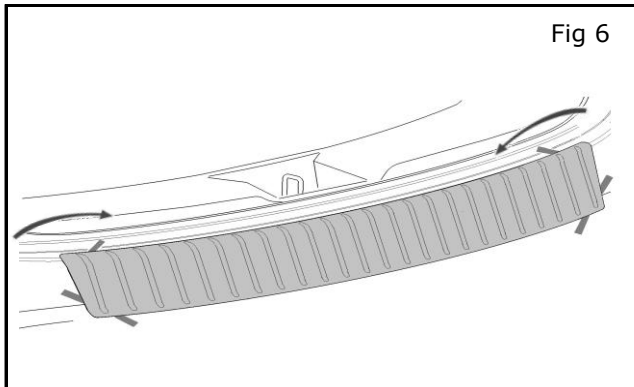

- 9) Remove spacer blocks.
- 10) While holding part in position with one hand at center arrow, remove only front tape liners.
- 11) Using a clean lint-free cloth, start at center and apply  $1 \text{ kg/cm}^2$  ( $15 \text{ lbs/in}^2$ ) of firm pressure along tape path.
- 12) Remove remaining tape liners.
- 13) Using a clean lint-free cloth, start at center and apply  $1 \text{ kg/cm}^2$  ( $15 \text{ lbs/in}^2$ ) of firm pressure along tape path.
- 14) To ensure adequate adhesion, re-apply  $1 \text{ kg/cm}^2$  ( $15 \text{ lbs/in}^2$ ) of firm pressure across entire part.

### CAUTION

**Failure to properly tack entire tape path to vehicle may allow bumper protector to peel up, loosen, and even detach over time.**

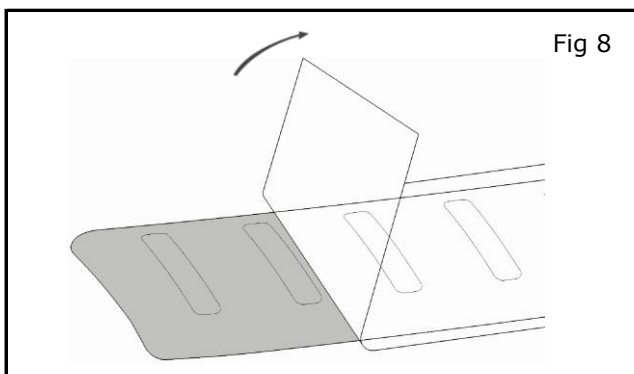

- 15) Remove and discard protective film.
- 16) Close rear hatch.
- 17) Maintain vehicle temperature between  $16^\circ\text{C}$  -  $43^\circ\text{C}$  ( $60^\circ\text{F}$  -  $110^\circ\text{F}$ ) for 2 hours, and do not expose vehicle to moisture for 24 hours.

### CAUTION

**To allow time for adhesive to cure, maintain vehicle temperature between  $16^\circ\text{C}$  -  $43^\circ\text{C}$  ( $60^\circ\text{F}$  -  $110^\circ\text{F}$ ) for 2 hour. Do not expose vehicle to moisture for 24 hours after installing bumper protector.**